

HSK DIN 69893 D

HSK DIN 69893 D

DIN 69893-1:1996-01- Form 'D' coolant through the flange

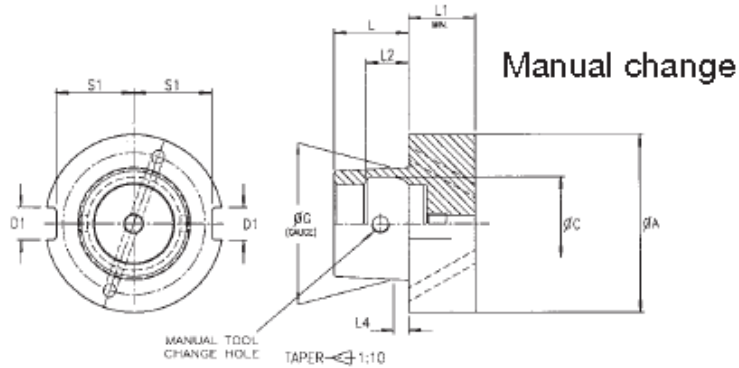

Coolant supply through the flange
 Enlarged flange diameter for rigidity
 Drive slots are in the flange
 For use on milling machines, lathes
 drilling and grinding machines, with
 manual tool change

HSK DIN 69893 Form 'D'									
Taper	A	C	G	D1	L	L1	L2	L4	S1
HSK40D	40.0	21.0	24.0	10.0	16.0	20.0	8.92	3.2	16.0
HSK50D	50.0	25.5	30.0	12.0	20.0	26.0	11.42	4.0	20.0
HSK63D	63.0	32.0	38.0	16.0	25.0	26.0	14.13	5.0	25.0
HSK80D	80.0	40.0	48.0	18.0	32.0	26.0	18.13	6.3	31.5
HSK100D	100.0	50.0	60.0	20.0	40.0	29.0	22.85	8.0	40.0