

HSK DIN 69893 B

HSK DIN 69893 B

DIN 69893-1:1996-01- Form 'B' coolant through the flange with automatic tool change

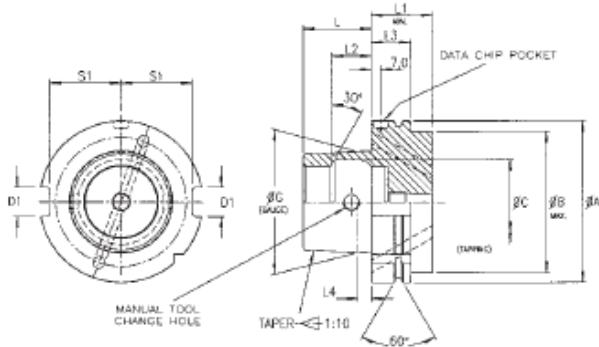

Coolant supply through the flange
 Enlarged flange diameter for rigidity
 Drive slots are in the flange
 For use on milling machines and lathes
 Machining centres with automatic tool change

HSK DIN 69893 Form 'B'											
Taper	A	B	C	G	D1	L	L1	L2	L3	L4	S1
HSK40B	40.0	34.0	21.0	24.0	10.0	16.0	35.0	8.92	20.0	3.2	16.0
HSK50B	50.0	42.0	25.5	30.0	12.0	20.0	42.0	11.42	26.0	4.0	20.0
HSK63B	63.0	53.0	32.0	38.0	16.0	25.0	42.0	14.13	26.0	5.0	25.0
HSK80B	80.0	67.0	40.0	48.0	18.0	32.0	42.0	18.13	26.0	6.3	31.5
HSK100B	100.0	85.0	50.0	60.0	20.0	40.0	45.0	22.85	29.0	8.0	40.0
HSK125B	125.0	105.0	63.0	75.0	25.0	50.0	45.0	28.56	29.0	10.0	50.0
HSK160B	160.0	130.0	80.0	95.0	32.0	63.0	47.0	36.27	31.0	12.5	62.5