

HSK DIN 69893 A

HSK DIN 69893 A

DIN 69893-1:1996-01- Form 'A' general purpose

TIMING DIMPLE

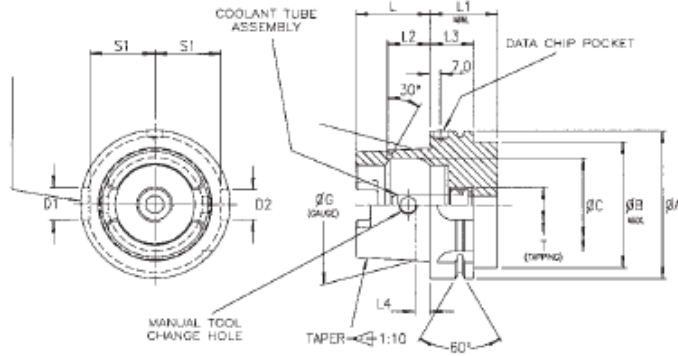

Standard type for use on milling machines and milling centres with automatic tool change. Also suitable for manual tool change.

Toolholder supplied less coolant tube assembly which must be ordered separately.

HSK DIN 69893 Form 'A'

Taper	A	B	C	G	D1	D2	L	L1	L2	L3	L4	S1	T
HSK32A	32.0	26.0	21.0	24.0	9.0	7.0	16.0	35.0	8.92	20.0	3.2	13.0	M10x1.0
HSK40A	40.0	34.0	25.5	30.0	11.0	9.0	20.0	35.0	11.42	20.0	4.0	17.0	M12x1.0
HSK50A	50.0	42.0	32.0	38.0	14.0	12.0	25.0	42.0	14.13	26.0	5.0	21.0	M16x1.0
HSK63A	63.0	53.0	40.0	48.0	18.0	16.0	32.0	42.0	18.13	26.0	6.3	26.5	M18x1.0
HSK80A	80.0	67.0	50.0	60.0	20.0	18.0	40.0	42.0	22.85	26.0	8.0	34.0	M20x1.0
HSK100A	100.0	85.0	63.0	75.0	22.0	20.0	50.0	45.0	28.56	29.0	10.0	44.0	M24x1.0
HSK125A	125.0	105.0	80.0	95.0	28.0	25.0	63.0	45.0	36.27	29.0	12.5	55.5	M30x1.0
HSK160A	160.0	130.0	100.0	120.0	36.0	32.0	80.0	47.0	45.98	31.0	16.0	72.0	M35x1.0