

GAGING AND INSPECTION

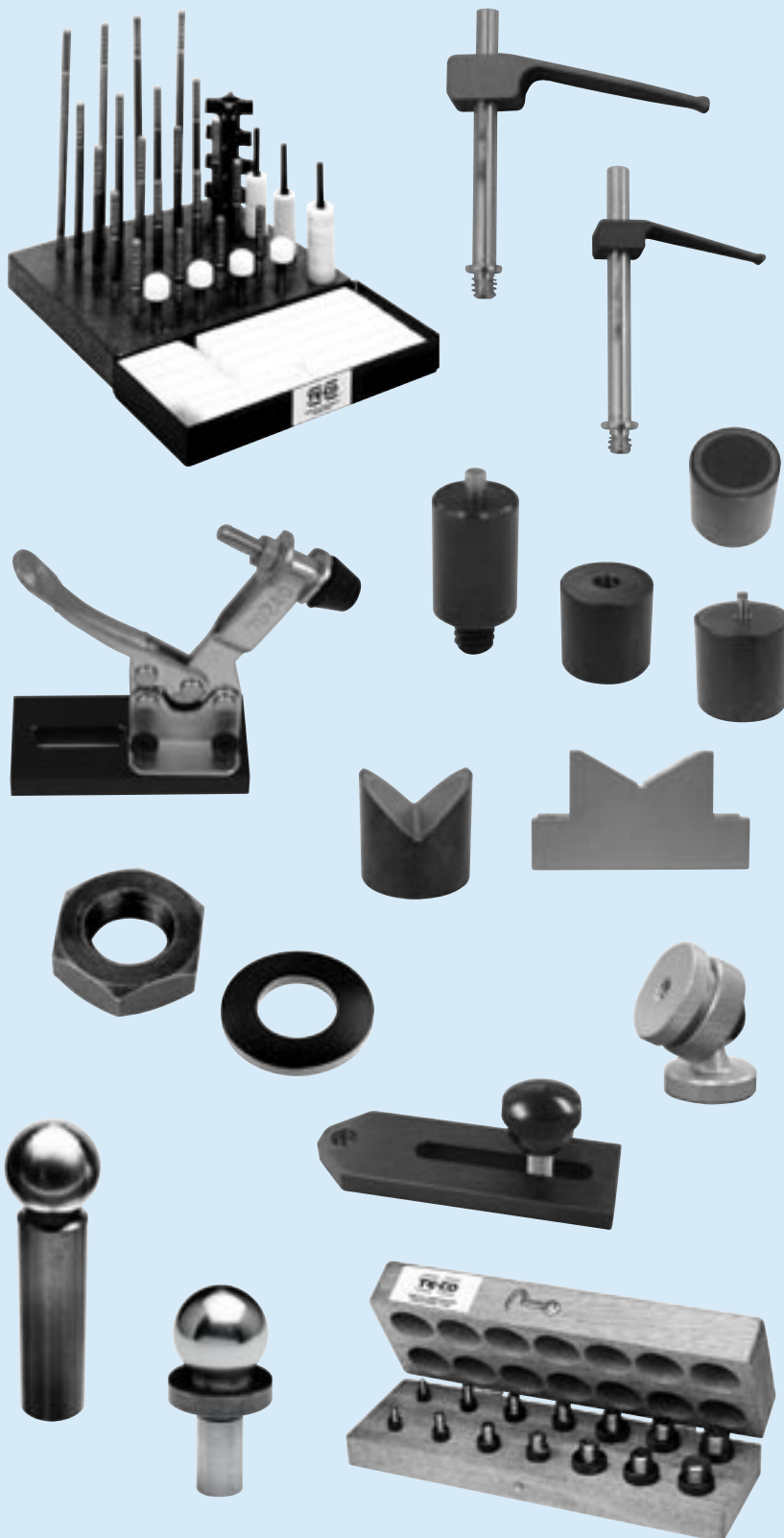

Fixture Plates.....	75
Fixturing Towers	76
CMM Fixturing Kits.....	77-78
Clamping Components	79-80
Standoffs and Locators.....	81-82
Magnetic Components	83-84
Height Adjustment	84
Positioners.....	85
Clamp Accessories.....	86
Plastic Clamp Kits	87
Steel Clamp Kits – English	88
Steel Clamp Kits – Metric.....	88
Tapped Hole Location Gages.....	89
Inspection Balls	90
Precision Balls.....	90
Tooling Balls	91
Construction Balls	92
Carbide Ball	92

TE-CO CMM FIXTURING SYSTEMS

Quick, Accurate, Repeatable.

Our new line of CMM fixturing is designed for easy assembly and high repeatability, without the added cost and inconvenience of having to build dedicated fixtures. This system offers a highly accurate and flexible solution for holding parts while probing. A variety of component kits and individual components are offered to provide the ability to quickly setup a fixture in a matter of minutes.

Summary of CMM Fixturing System Features:

Aluminum Plates – 3 standard plate sizes are offered. TE-CO will quote custom plates to accommodate the measuring ranges of specific models of CMMs. Standard plates are black anodized with 1/4-20 holes on 1/2" centers and are alpha numerically labeled for repeatable setups.

Component Kits – Component kits are sold separately from plates. Plate purchases are not required to purchase component kits or individual components. The basic kit, the comprehensive kit, and the magnetic component pack all come with wooden holders to provide a simple, effective method of storage.

Soft Touch Clamp – This aluminum clamping arm provides the light clamping force ideal for soft touch probing with a coordinate measuring machine.

Locating Components – Several diameters and lengths of standoffs and rest pads are available to elevate and position parts without restricting access to them.

Magnetic Components – Magnetic rest pads, magnetic vees, and magnetic pin rests are available to hold steel and iron parts.

Adjustable Components – A variety of components are available that provide height adjustment, vee alignment, and flexible hole location.

Component Thread Size – Standard components are 1/4-20 thread size. TE-CO will quote components with alternative thread sizes upon request.

Thread Adapters – Adapters are available to convert components between 1/4-20 and 5/16-18 thread sizes.

PLATES

Aluminum Fixture Plates

- Alpha numeric grid pattern
- Black hard coat anodized
- 1/4-20 tapped holes

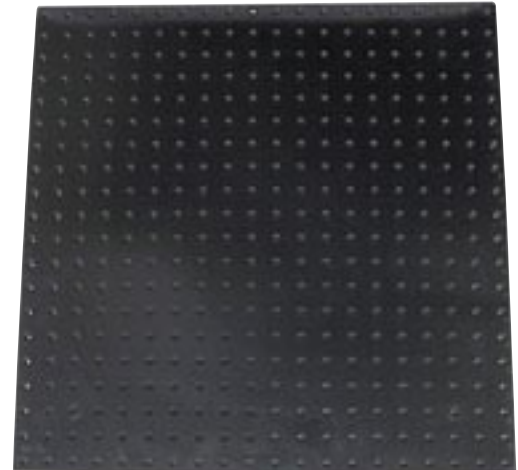
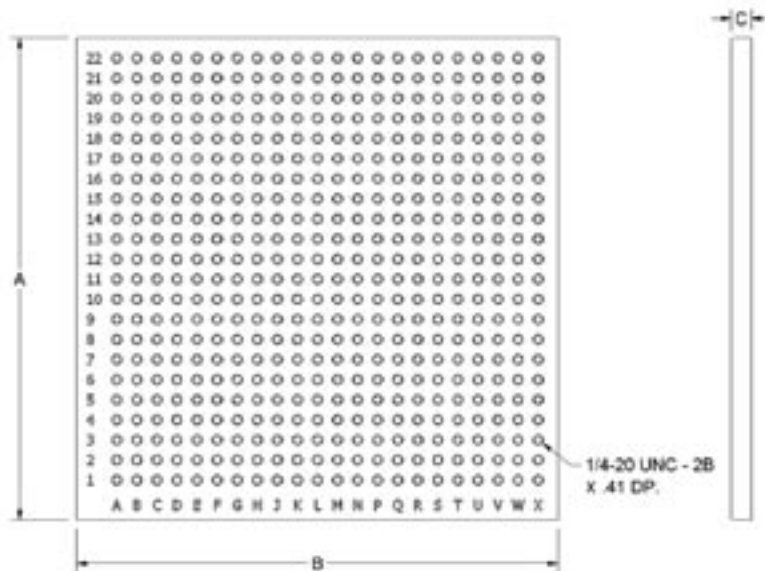

GAGING AND INSPECTION

Custom plate sizes will be quoted upon request

Part No.	Length A	Width B	Thickness C	Hole Spacing
14312	12"	12"	1/2"	1/2" Centers
14318	18"	18"	1/2"	1/2" Centers
14324	24"	24"	3/4"	1/2" Centers

Acrylic Plates for Vision System Fixturing

TE-CO's CMM fixturing components are also ideal for use with vision systems in conjunction with acrylic plates with 1/4-20 tapped holes. Although standard acrylic plates are not currently available, inquiries on custom acrylic plates or 1/4-20 component packages for vision fixturing are welcomed. Contact our customer service department today for details at sales@te-co.com or 1-800-543-4071.



FIXTURING TOWERS

Fixturing Towers

- For vertical fixturing
- 1/4-20 tapped holes
- Holes alpha numerically labeled for repeatability
- Each tower includes a base with 2 knurled knob studs

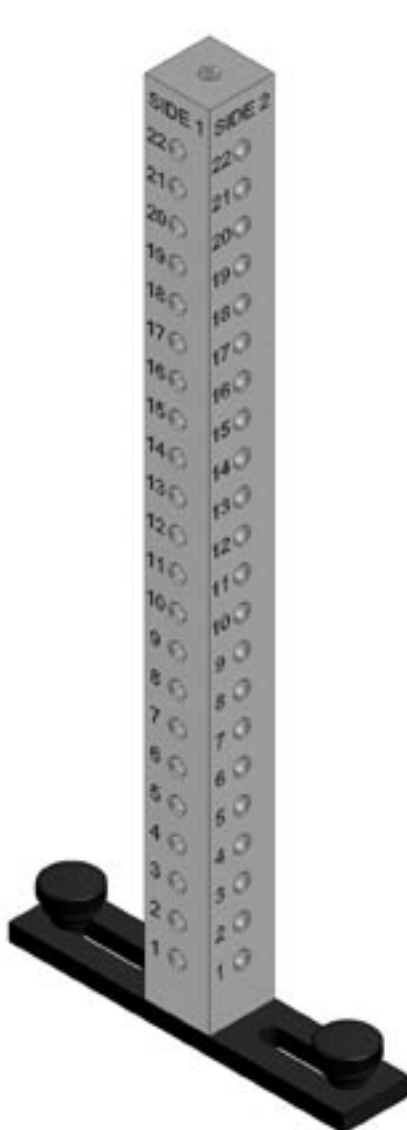

Single Hole Rows

Part No.	Width A	Height B	Hole Rows
14350	1"	6"	1
14355	1"	12"	1

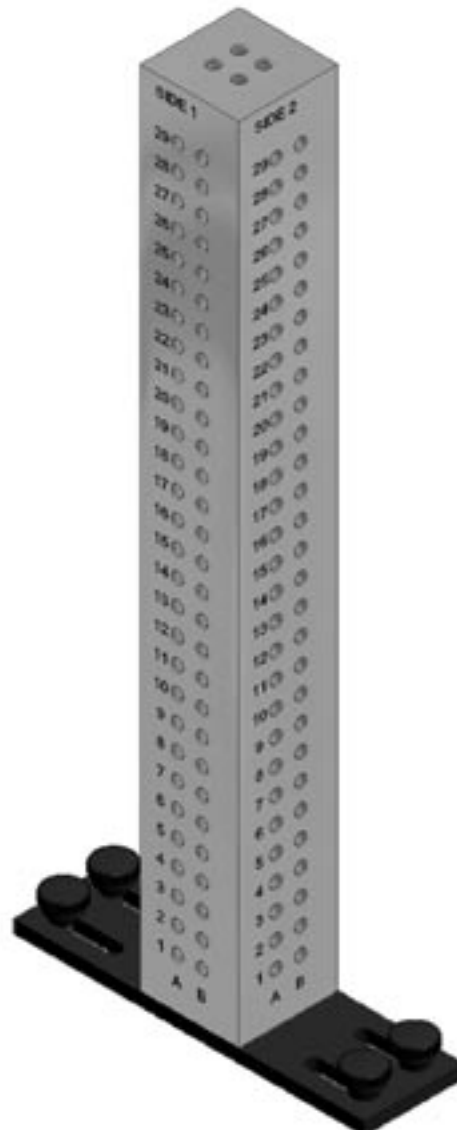

Double Hole Rows

Part No.	Width A	Height B	Hole Rows
14365	2"	16"	2
14370	2"	20"	2
14375	2"	30"	2

CMM FIXTURING KITS

Component Kits Can Be Purchased With or Without Purchasing a Plate

The Basic Kit, The Comprehensive Kit, and The Magnetic Component Pack all come with Wooden Holders for Convenient Storage.

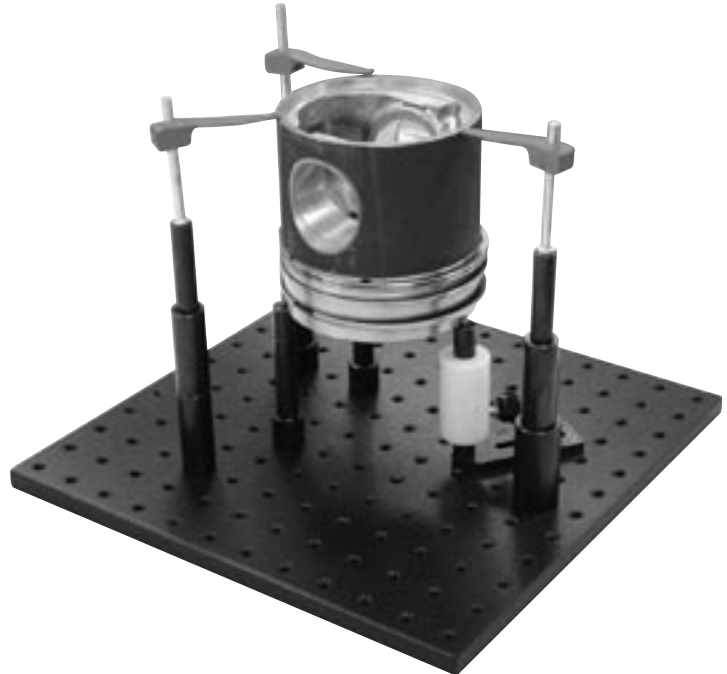

GAGING AND INSPECTION

Basic Kit: Part No. 14301

- Designed for clamping non-magnetic parts
- Use with plastic, aluminum and steel
- Ideal to combine with Magnetic Component Pack

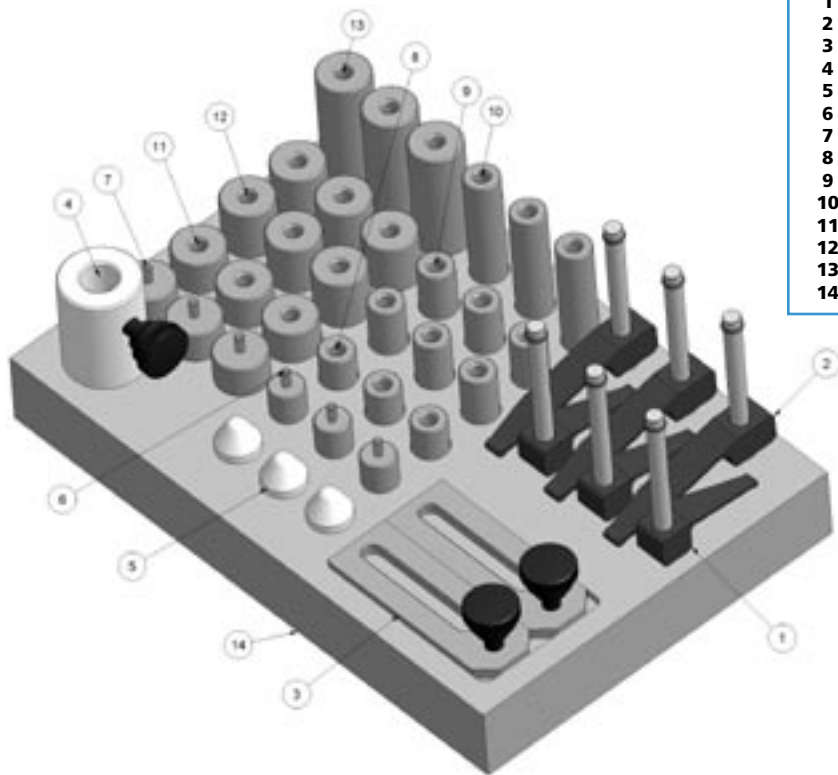

Item No.	Part No.	Description	Qty.
1	14060	Small Soft Touch Clamp	3
2	14064	Large Soft Touch Clamp	3
3	14034	Large Adjustable Positioner	2
4	14201	Delrin Height Adjuster	1
5	14075	Delrin Cones	3
6	14040	1/2" Dia. x 1/2" Height Pin Rest	3
7	14041	3/4" Dia. x 1/2" Height Pin Rest	3
8	14017	1/2" Dia. x 3/4" Height Standoff	3
9	14018	1/2" Dia. x 1" Height Standoff	6
10	14019	1/2" Dia. x 2" Height Standoff	3
11	14022	3/4" Dia. x 3/4" Height Standoff	3
12	14023	3/4" Dia. x 1" Height Standoff	6
13	14024	3/4" Dia. x 2" Height Standoff	3
14	40091	Wooden Component Holder	1

Comprehensive Kit: Part No. 14302

- Developed to allow added flexibility
- Use with plastic, aluminum and steel

Item No.	Part No.	Description	Qty.
1	14060	Small Soft Touch Clamp	3
2	14064	Large Soft Touch Clamp	3
3	14034	Large Adjustable Positioner	2
4	14201	Delrin Height Adjuster	1
5	14215	1/2" Dia. Screw Jack	1
6	14075	Delrin Cones	6
7	14082	Swivel Joint Rest	2
8	14158	Small Toggle Clamp with Pad	2
9	14040	1/2" Dia. x 1/2" Height Pin Rest	3
10	14041	3/4" Dia. x 1/2" Height Pin Rest	3
11	14017	1/2" Dia. x 3/4" Height Standoff	3
12	14018	1/2" Dia. x 1" Height Standoff	6
13	14019	1/2" Dia. x 2" Height Standoff	3
14	14022	3/4" Dia. x 3/4" Height Standoff	3
15	14023	3/4" Dia. x 1" Height Standoff	6
16	14024	3/4" Dia. x 2" Height Standoff	3
17	14027	1" Dia. x 3/4" Height Standoff	3
18	14028	1" Dia. x 1" Height Standoff	6
19	14029	1" Dia. x 2" Height Standoff	3
20	40090	Wooden Component Holder	1

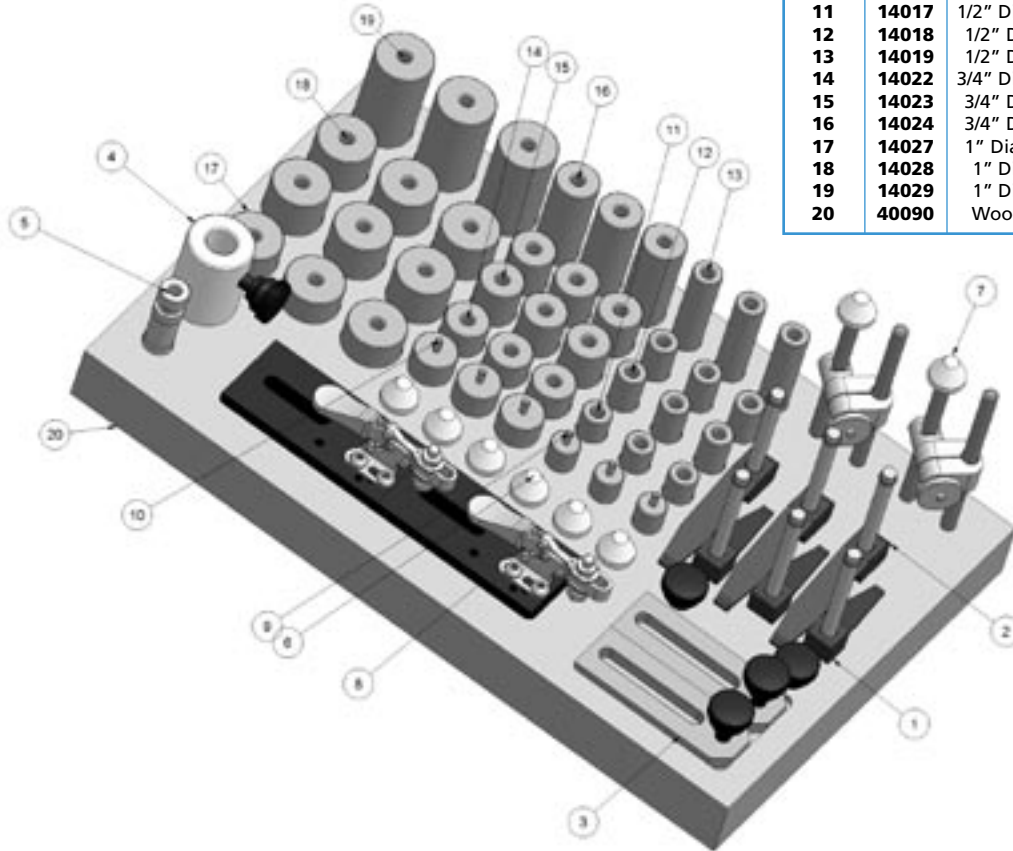

Magnetic Component Pack: Part No. 14303

- Magnets optimize access for probing of steel parts
- Use with steel & iron

Item No.	Part No.	Description	Qty.
1	14102	1/2" Dia. x 1" Height Magnetic Rest Pad	3
2	14103	3/4" Dia. x 1" Height Magnetic Rest Pad	3
3	14132	1/2" Dia. x 1" Height Magnetic Pin Rest	3
4	14133	3/4" Dia. x 1" Height Magnetic Pin Rest	3
5	14141	1/2" Dia. x 1" Magnetic V Standoff	2
6	14143	1" Dia. x 1" Height Magnetic V Standoff	2
7	40092	Wooden Component Holder	1

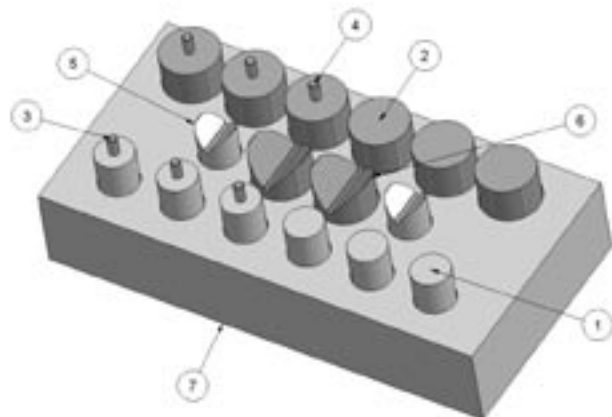

CLAMPING

Soft Touch Clamps

- Ideal for light pressure clamping
- Made of aluminum

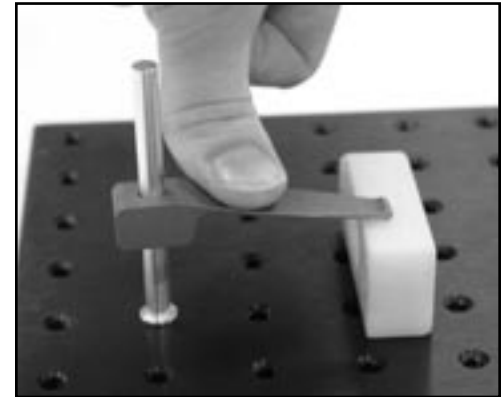
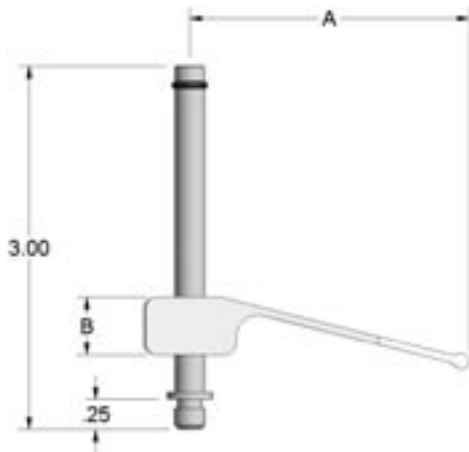

GAGING AND INSPECTION

Part No.	A	B
14060	1.75	.312
14064	2.31	.477

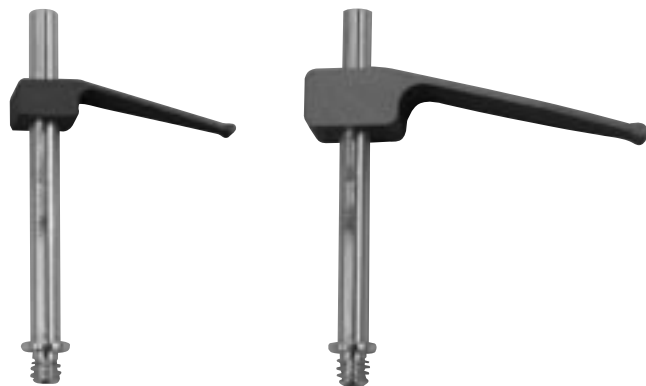

Small Toggle Clamp with Pad

- Holds parts for probing
- Base adjusts for placement
- Includes Knurled Knob Stud to lock in place

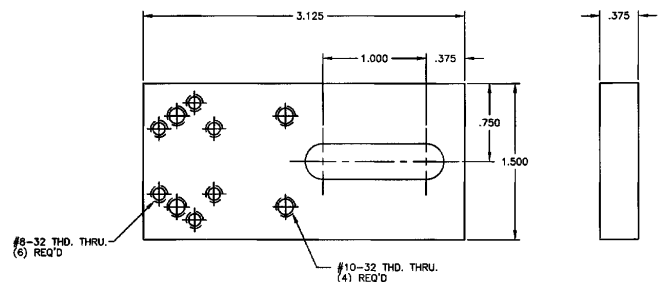

Part No.	A	B	C	D	E	G	H	J
14158	3/4	5/16	2-21/32	5/8	5/8	5/16	5/32	11/16

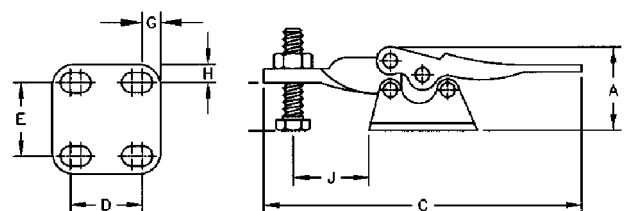

T-Handle Spring Stop with Pad

- Provides horizontal clamping
- T-Handle allows for quick changeover
- Base adjusts for placement
- Includes Knurled Knob Stud to lock in place

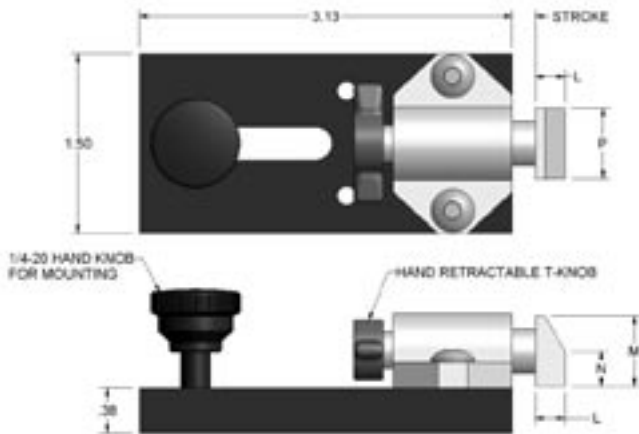
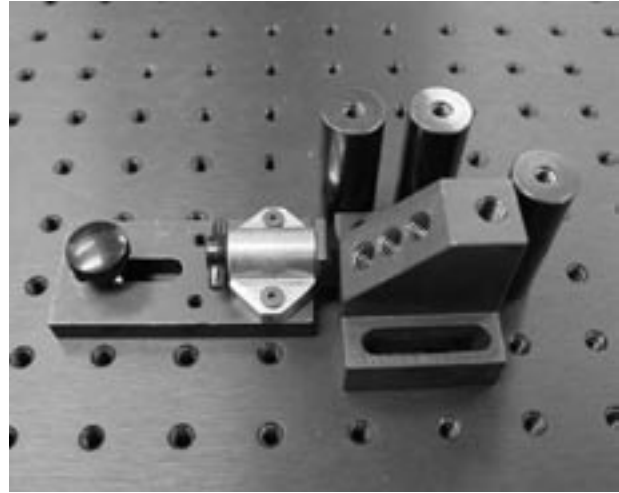

Part No.	L	M	N
14160	1/4	15/16	5/16

Large Toggle Clamp with Pad

- Holds parts for probing
- Base adjusts for placement
- Includes Knurled Knob Stud to lock in place

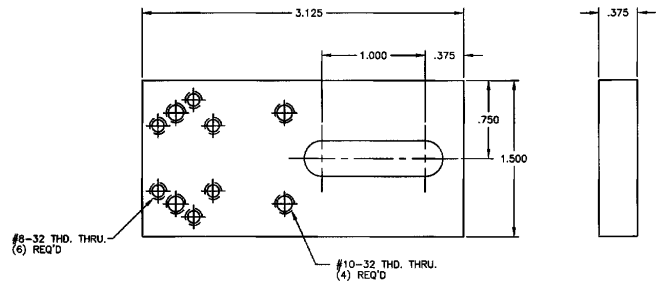

PROVIDES MOUNTING FOR 53101-34105-34110

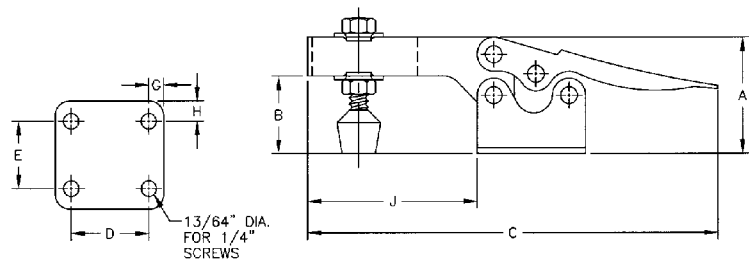

Part No.	A	B	C	D	E	G	H	J
14159	1-1/2	1	5-7/16	1-1/16	7/8	3/16	17/64	2-1/4

STANDOFFS/LOCATORS

Adjustable Positioner

- Allows for flexible hole placement
- Includes Knurled Knob Stud to lock in place

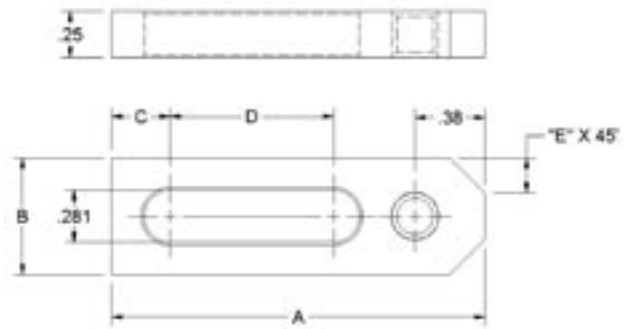

Part No.	Length A	Width B	C	D
14033	2.00	.625	.313	1.312
14034	3.00	1.00	.313	2.312

GAGING AND INSPECTION

Standoffs

- Provides resting point to elevate part for probing

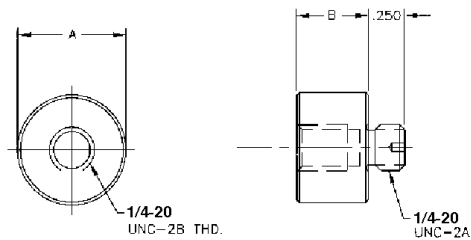

Part No.	Dia. A	Height B
14016	.500	.500
14017	.500	.750
14018	.500	1.00
14019	.500	2.00
14020	.500	3.00

Part No.	Dia. A	Height B
14021	.750	.500
14022	.750	.750
14023	.750	1.00
14024	.750	2.00
14025	.750	3.00

Part No.	Dia. A	Height B
14026	1.00	.500
14027	1.00	.750
14028	1.00	1.00
14029	1.00	2.00
14030	1.00	3.00

Double-Sided Adhesive Squares

- Place adhesive square between standoff and part
- Increases part access for probing
- Quick changeover
- Leaves minimal residue

Part No.	Length A	Width B	Quantity
14210	1"	1/2"	10 squares



Pin Rest

- Provides point of rest and side stop for locating

Part No.	Dia. A	Height B
14040	.500	.500
14041	.750	.500

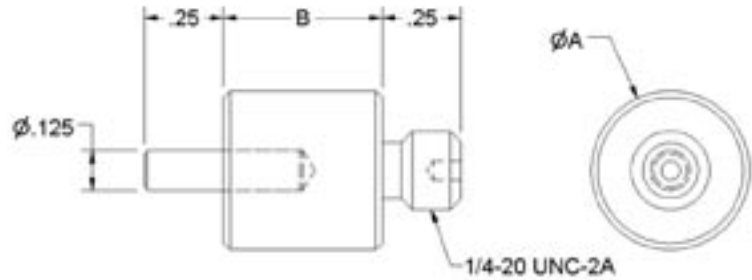

GAGING AND INSPECTION

Thread Adapter

- Converts between 1/4-20 & 5/16-18

Part No.	A	B	C	D
13085	1.00	1.00	1/4-20	5/16-18
13086	1.00	1.00	5/16-18	1/4-20

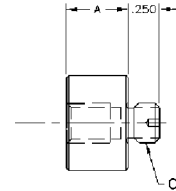
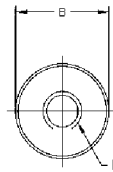

Delrin® Cone

- For nesting cylindrical or curved parts
- Delrin offers nonmarring attribute
- Also provides resting point without limiting access to part

Part No.	Dia. A	Height B
14075	.625	.500



MAGNETIC COMPONENTS

Magnetic Rest Pad

- For fixturing steel or iron parts
- Magnetic force holds parts during probing

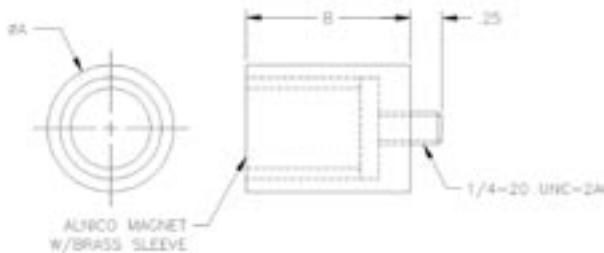

Part No.	Dia. A	Height B
14101	.250	1.00
14102	.500	1.00
14103	.750	1.00
14104	1.00	1.00

Magnetic Vee Standoff

- To fixture cylindrical steel or iron parts
- Magnetic force holds parts during probing
- Holder on page 84

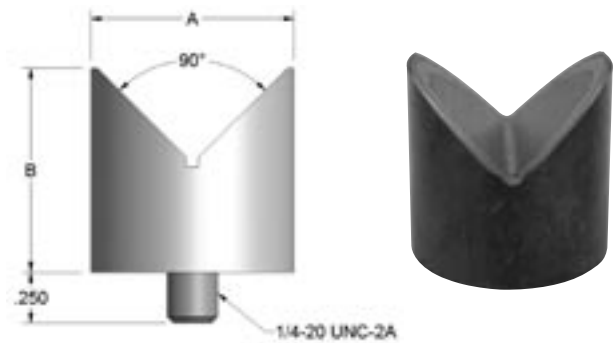

Part No.	Dia. A	Height B	Holding Capacity	Holder Part No.
14141	.500	1.00	.125-.625" Dia.	14162
14143	1.00	1.00	.125-1.25" Dia.	14164

GAGING AND INSPECTION

Magnetic Pin Rest

- Locates and holds steel or iron parts during probing

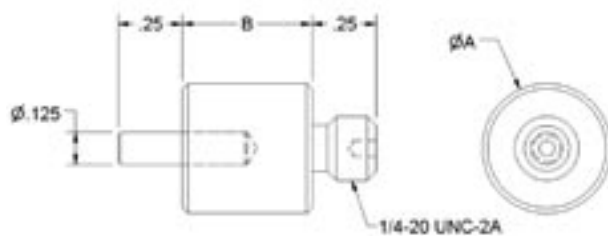

Part No.	Dia. A	Height B
14132	.500	1.00
14133	.750	1.00
14134	1.00	1.00

Magnetic Vee Block

- For holding large cylindrical steel or iron parts
- Includes 2 cap screws to fasten to plate

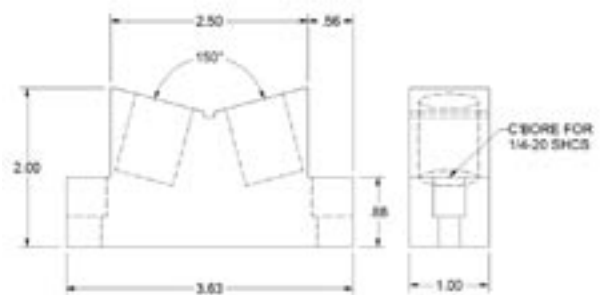

Part No.	Holding Capacity
14150	2.00-6.25" Dia.

Delrin® Holder for Magnetic Vee Standoffs

- For aligning multiple vees to hold cylindrical parts

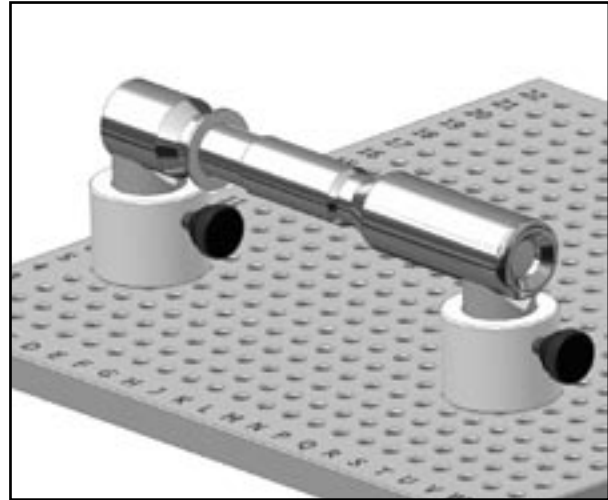

Part No.	Internal Dia. A	Internal Depth B	Use With
14162	.500	.625	14141
14164	1.00	.500	14143

HEIGHT ADJUSTMENT

Delrin® Height Adjuster

- Slips over 1/2" diameter standoffs
- Knurled knob stud quickly tightens for height adjustment
- Standoffs sold separately

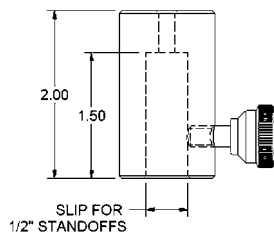
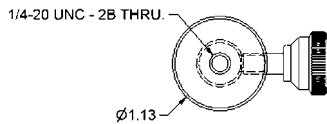

Part No.	Internal Dia. A	Internal Depth B
14201	.500	1.50

Screw Jack

- Allows for fine height adjustment during probing
- Made of aluminum

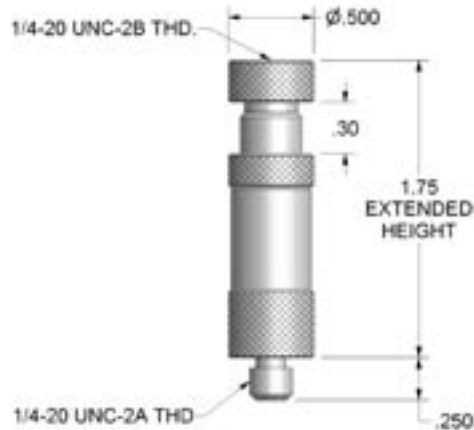

Part No.	Dia. A	Height Ranges
14215	.500	1.45 to 1.75

POSITIONERS

Adjustable Ball Positioner

- For holding parts at an angle
- Pivots approximately 45° from horizontal in every direction
- Collar easily rotates and tightens on ball at variable angles
- Cylindrical top contains centered 1/4-20 tapped holes

Part No.
14225

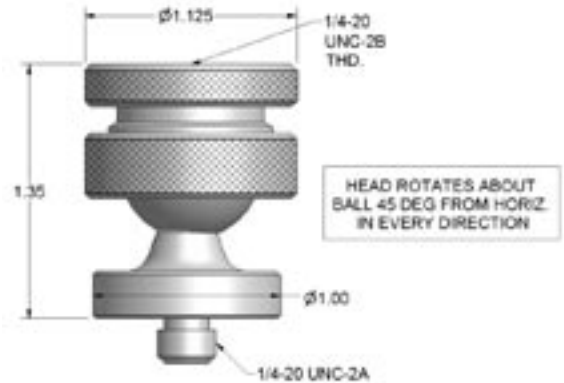

GAGING AND INSPECTION

Toggle Pad

- Pad swivels 10° from vertical in all directions
- Assures positive gripping

Part No.	A	B	C	D	E
44302	1/4-20	.625	.625	.500	.4063

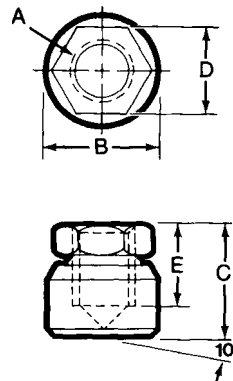

Swivel Joint Rest

- Rotates 360° side-to-side and up-and-down
- Arm extends and retracts
- Rotating arm features Delrin Cone for positioning part

Part No.	Length of Rods
14082	4"



CLAMP ACCESSORIES

Knurled Knob with Stud

For use with Adjustable Positioner, Toggle Clamp and Side Stop Pads, Delrin Height Adjuster, Delrin Vee Standoff Positioner, and Fixturing Towers.



Part No.	Thread Size
14203	1/4-20

Cap Screw

- For use With Magnetic Vee Block



Part No.	Thread Size	Thread Length
RSB4503	1/4-20	3/4

Clamp Support

- For use with Step Blocks & Clamps
- Includes washer, spring and shaft collar
- Black oxide finish (washer only)

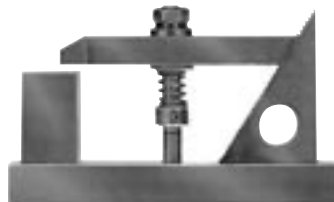
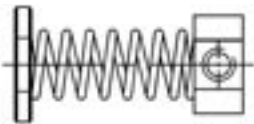

Part No.	Stud Size	Weight (lbs/kit)
50801	1/4	4
50802	5/16	4
50803	3/8	8
50804	1/2	12
50805	5/8	19
50806	3/4	26
50808	1	31

Hex Jam Nuts

- Black oxide finish
- High grade alloy steel
- Will outlast ordinary Hex Jam Nuts when used in repetitive operations

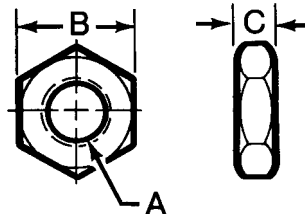

Part No.	Thread A	B	C	Weight (lbs/100pcs)
42201	1/4-20	1/2	11/64	1

Hardened Flat Washer

- Black oxide finish and case hardened
- Material: C1010 Steel
- Many sizes conform to TCMAI standards
- Large quantities quoted upon request

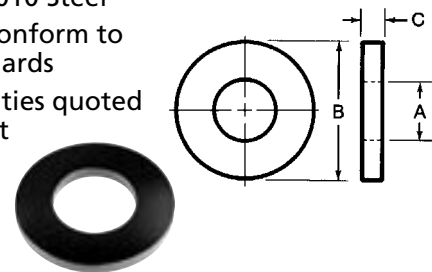

Steel Part No.	Stud Size	A	B	C	Weight (lbs/100pcs)
42601	1/4	9/32	5/8	1/8	1

Plastic Clamp Kit

The TE-CO Plastic Clamp Kit is designed exclusively for the CMM inspection, laboratory inspection and gaging applications. The lightweight construction prevents possible damage to granite plates, delicate workpieces, costly inspection fixtures, and expensive laboratory instruments.

The plastic construction of the kit can help eliminate damage to painted, plated or finished surfaces while minimizing distortion of plastic or slender shapes. The hand-tightening design of the kit allows the user to apply optimum hold down force and prevent possible damage to granite plate inserts. This unique, non-marking clamping kit is designed to meet today's demanding inspection needs.

- Kits are used to properly hold down workpiece during workpiece inspection
- Eliminates marring of workpiece surface
- Lightweight construction minimizes part distortion
- Reduces risk of damage to surface plate or CMM table

Kit Contains:

- **24 Steel Studs**
 - 4 each of 2, 3, 4, 5, 6, & 8" lengths
 - Part #12110 does not include 8" length studs
- **12 Plastic Clamps**
 - 4 each of 2.5, 4 & 6" lengths
 - Part #12110 includes 4 each of 2.5", 3.5", & 4.5" lengths (4" & 6" lengths not included)
- **4 Coupling Nuts**
- **4 Plastic Hand Knobs**
- **4 Plastic Rest Feet**
- **8 Washers**
- **1 Holder (metal tray)**

Material:

- Clamps, Rest Feet: Nylon 101
- Studs, Coupling Nuts & Washers: Steel



GAGING AND INSPECTION

Individual Components Available upon Request

English

Part No.	Thread Size
*12110	1/4-20
12111	5/16-18
12112	3/8-16

Metric

Part No.	Thread Size
12210	8MM
12211	10MM
12212	12MM

*Composition differs slightly

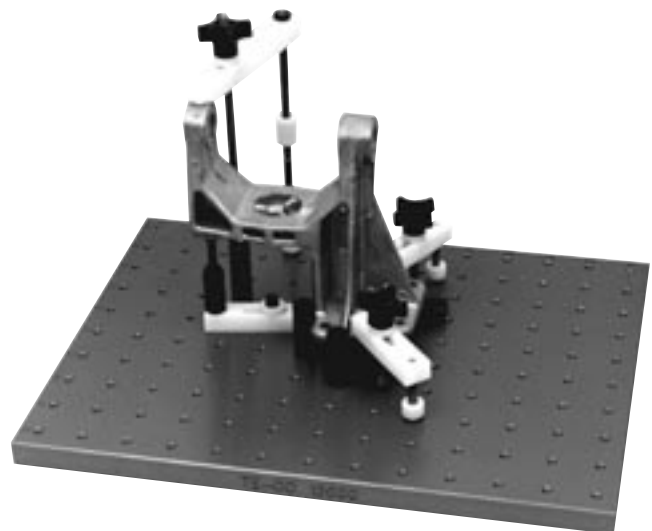

Plastic Clamps are NOT recommended for machining purposes.

English Coordinate Measuring Machine Clamp Kits

- For material information, see individual components.
- Kits are used to properly hold down workpiece during workpiece inspection.
- Kit Contains:
 - 8 Coupling Nuts
 - 8 Flange Nuts
 - 2 Serrated End Clamps: 2-1/2" O.A.L.
 - 2 Serrated End Clamps: 4" O.A.L.
 - 2 Serrated End Clamps: 6" O.A.L.
 - 2 Steel Step Blocks (Max. Height 1-5/8")
 - 2 Steel Step Blocks (Max. Height 2-1/2")
 - 2 Steel Step Blocks Max. Height 6"
 - 24 Studs: 4 Each of 3", 4", 5", 6", 7" & 8" long
 - 1 Holder
- Optional T-Slot Nuts available



Part No.	Stud Size	Step Blocks (2 each)	Serrated End Clamps (2 each)
12105	5/16-18	40102	30501
		40103	30502
		40104	30503
12106	3/8-16	40102	30501
		40103	30502
		40104	30503

Optional T-Slot Nuts

Part No.	Stud Size	Table T-Slot	
		English	Metric
41403	5/16-18	3/8	10MM
41404	3/8-16	7/16	12MM

Metric Coordinate Measuring Machine Clamp Kits

- For material information, see individual components.
- Kits are used to properly hold down workpiece during workpiece inspection.
- Kit Contains:
 - 8 Coupling Nuts
 - 8 Flange Nuts
 - 2 Serrated End Clamps: 64mm O.A.L.
 - 2 Serrated End Clamps: 102mm O.A.L.
 - 2 Serrated End Clamps: 152mm O.A.L.
 - 2 Steel Step Blocks (Max. Height 41mm)
 - 2 Steel Step Blocks (Max. Height 64mm)
 - 2 Steel Step Blocks (Max. Height 152mm)
 - 4 Each of 80mm, 110mm, 140mm, 155mm, 175mm & 200mm long
 - 1 Holder
- Optional T-Slot Nuts available



Part No.	Stud Size	Step Blocks (2 each)	Serrated End Clamps (2 each)
12205	M8 x 1.25	40102	30501
		40103	30502
		40104	30503
12206	M10 x 1.50	40102	30501
		40103	30502
		40104	30503
12207	M12 x 1.75	40102	30504
		40103	30505
		40104	30506

Optional T-Slot Nuts

Part No.	Stud Size	Table T-Slot	
		English	Metric
61403	M8 x 1.25	10MM	7/16
61404	M10 x 1.50	12MM	1/2
61406	M12 x 1.75	14MM	9/16

Tapped Hole Location Gages

- Material:
 - Body: 52100 Steel
 - Collar: 12L14 Steel
- Black Oxide Finish on collar only
- Two piece construction
- Use to accurately measure the distance between two tapped holes in a workpiece
- Shaft size is the same diameter on all gages to simplify calculation of the hole spread
 - All diameters are concentric within .0002 T.I.R.
- English:
 - Thread Class: 3A
 - Left-hand thread, helicoil, or other non-standard gages quoted upon request
- Metric:
 - Thread Class: 6G
 - ISO metric fine pitch thread, left-hand thread, helicoil, or other non-standard gages quoted upon request

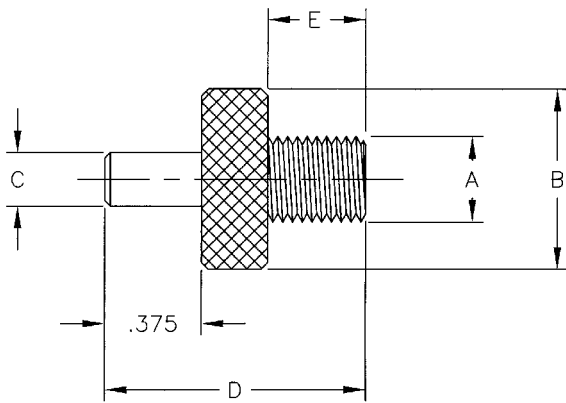

UNF Sizes

Part No.	Thread A	Dia. B	Dia. C*	D	E	Weight (lbs/100pcs)
10321	6-40	5/16	.2500	7/8	1/4	1
10309	10-32	5/16	.2500	7/8	1/4	1
10310	1/4-28	3/8	.2500	1	3/8	2
10311	5/16-24	1/2	.2500	1	3/8	3
10312	3/8-24	1/2	.2500	1	3/8	3
10313	7/16-20	7/8	.2500	1	3/8	4
10314	1/2-20	7/8	.2500	1	3/8	6
10315	5/8-18	7/8	.2500	1	3/8	6

*C Diameter: +.0002/-0.0000

UNC Sizes

Part No.	Thread A	Dia. B	Dia. C*	D	E	Weight (lbs/100pcs)
10317	2-56	5/16	.2500	7/8	5/16	1
10318	4-40	5/16	.2500	7/8	5/16	1
10319	5-40	5/16	.2500	7/8	5/16	1
10320	6-32	5/16	.2500	7/8	5/16	1
10322	8-32	5/16	.2500	7/8	5/16	1
10301	10-24	5/16	.2500	7/8	5/16	1
10302	1/4-20	3/8	.2500	1	3/8	3
10303	5/16-18	1/2	.2500	1	3/8	3
10304	3/8-16	1/2	.2500	1	3/8	3
10305	7/16-14	7/8	.2500	1	3/8	4
10306	1/2-13	7/8	.2500	1	3/8	6
10307	5/8-11	7/8	.2500	1	3/8	6
10330	3/4-10	1	.2500	1-1/8	1/2	12

*C Diameter: +.0002/-0.0000

Metric Sizes

Part No.	Thread A	Dia. B	Dia. C*	D	E	Weight (lbs/100pcs)
11101	M1.6 x .35	7.95	6.35	22	6.35	0.90
11103	M2.0 x .40	7.95	6.35	22	6.35	1.00
11105	M2.5 x .45	7.95	6.35	22	6.35	1.00
11107	M3.0 x .50	7.95	6.35	22	6.35	1.00
11109	M4.0 x .70	7.95	6.35	22	6.35	1.00
11111	M5.0 x .80	9.53	6.35	22	6.35	1.40
11113	M6.0 x 1.00	9.53	6.35	22	6.35	1.50
11121	M8.0 x 1.25	12.7	6.35	28	12.70	2.70
11123	M10 x 1.50	12.7	6.35	28	12.70	4.50
11125	M12 x 1.75	22.23	6.35	28	12.70	5.50
11127	M16 x 2.0	22.23	6.35	28	12.70	7.50
11129	M20 x 2.50	25.4	6.35	28	12.70	12.00

*C Diameter: +.0002/-0.0000

English Tapped Hole Location Gage Kits

- Each kit includes a wooden storage box
- Special kits can be assembled to meet your requirements.

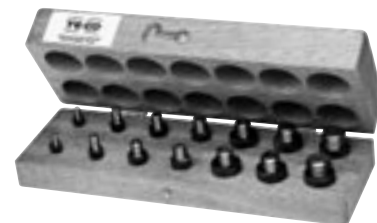

UNF Kit

Part No.	Weight (lbs/kit)	2 Thread	Each
10316	1	10-32	10309
		1/4-28	10310
		5/16-24	10311
		3/8-24	10312
		7/16-20	10313
		1/2-20	10314
		5/8-18	10315

UNC Kit

Part No.	Weight (lbs/kit)	2 Thread	Each
10308	1	10-24	10301
		1/4-20	10302
		5/16-18	10303
		3/8-16	10304
		7/16-14	10305
		1/2-13	10306
		5/8-11	10307

Part No.	Weight (lbs/kit)	2 Thread	Each
10323	1	2-56	10317
		4-40	10318
		5-40	10319
		6-32	10320
		6-40	10321
		8-32	10322

Premium Short Shank Inspection Ball

- Material: 8620 Steel
- Case hardened
- One-piece construction
- Used as reference points for inspection applications in conjunction with Coordinate Measuring Machines to accurately measure the workpiece
- Concentricity of Ball to Shank - .0001 T.I.R.



Part No.	Dia. A*	Dia. B**	C	D***	Thread E	Dia. F	Weight (lbs/100pcs)
10601	0.2500	0.1247	0.58	.2000		1/4	1
10602	0.3750	0.1872	0.74	.3000		3/8	1
10603	0.3750	0.3125	0.74	.3000	8-32	1/2	3
10604	0.5000	0.2497	0.63	.3125	6-32	1/2	3
10605	0.5000	0.2497	0.93	.4000	6-32	1/2	3
10606	0.5000	0.2497	0.88	.5000	6-32	1/2	3
10607	0.5000	0.3750	1.31	.3750	10-24	5/8	6
10608	0.6250	0.3122	1.08	.4500	8-32	5/8	6
10609	0.6250	0.3750	1.42	.4500	10-24	5/8	7
10610	0.6875	0.3750	1.47	.5000	10-24	3/4	9
10611	0.7500	0.3750	1.53	.5625	10-24	3/4	13
10612	1.0000	0.5000	1.64	.7000	10-24	1	25

*A Diameter: +.0000/-.0002

**B Diameter: +.0000/-.0002

***D: +/- .0002

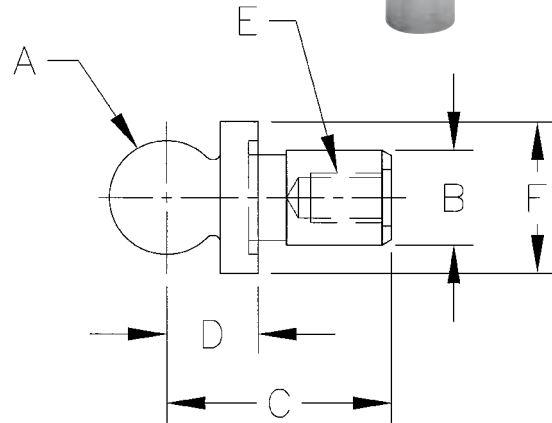

Premium Short Shank Inspection Ball Kit

- Each kit includes a wooden storage box
- Special kits can be assembled to meet your requirements.



Part No.	1 Each	
10613	10601	10605
	10602	10606
	10603	10608
	10604	

Precision Ball Precision Slip Fit Shoulder Ball

- Used as reference points for inspection applications in conjunction with Coordinate Measuring Machines to accurately measure the workpiece
- Concentricity of Ball to Shank - .0002 T.I.R.
- Hardened and ground steel (440 Stainless)
- Two-piece construction

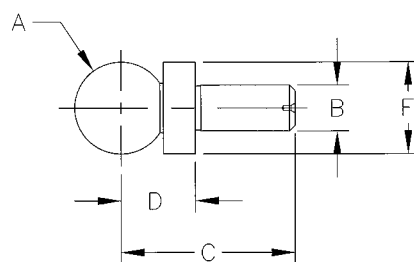

Part No.	Dia. A*	Dia. B**	C	D***	Dia. F	Weight (lbs/100pcs)
10850	0.25000	0.1247	9/16	.2000	1/4	1
10851	0.37500	0.1872	3/4	.3000	3/8	1
10852	0.50000	0.2497	15/16	.4000	1/2	3
10853	0.62500	0.3122	1-1/16	.4500	5/8	6
10854	0.75000	0.3747	1-1/4	.5000	3/4	10
10855	0.87500	0.4372	1-7/16	.6000	7/8	7
10856	1.00000	0.4997	1-5/8	.7000	1	24

*A Diameter: +/- .0005

**B Diameter: +.0000/-.0002

***D: +/- .0002

Tooling Balls Shoulder Tooling Balls

- Used as reference points for inspection applications in conjunction with Coordinate Measuring Machines to accurately measure the workpiece
- Concentricity of Ball to Shank - .0002 T.I.R.
- Hardened and ground steel (8620 Stainless)
- One-piece construction

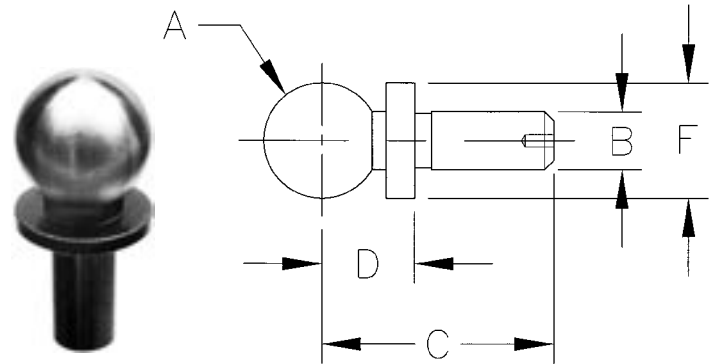

Slip Fit

Part No.	Dia. A*	Dia. B**	C	D***	Dia. F	Weight (lbs/100pcs)
10801	0.2500	0.1250	9/16	.2000	1/4	1
10802	0.3750	0.1875	3/4	.3000	3/8	1
10803	0.5000	0.2500	15/16	.4000	1/2	3
10804	0.5000	0.2500	1-3/8	.5000	1/2	4
10805	0.7500	0.3750	1-1/4	.5000	3/4	10

*A Diameter: $\pm .0002$
 **B Diameter: $+ .0000 / - .0004$
 ***D: $\pm .0002$

Press Fit

Part No.	Dia. A*	Dia. B**	C	D***	Dia. F	Weight (lbs/100pcs)
10901	0.2500	0.1253	9/16	.2000	1/4	1
10902	0.3750	0.1878	3/4	.3000	3/8	1
10903	0.5000	0.2503	15/16	.4000	1/2	3
10904	0.5000	0.2503	1-3/8	.5000	1/2	4
10905	0.7500	0.3753	1-1/4	.5000	3/4	10

*A Diameter: $\pm .0002$
 **B Diameter: $+ .0003 / - .0000$
 ***D: $\pm .0002$

Standard Tooling Ball

- Used as reference points for inspection applications in conjunction with Coordinate Measuring Machines to accurately measure the workpiece
- Concentricity of Ball to Shank - .0002 T.I.R.
- Hardened and ground steel (8620 Stainless)
- One-piece construction

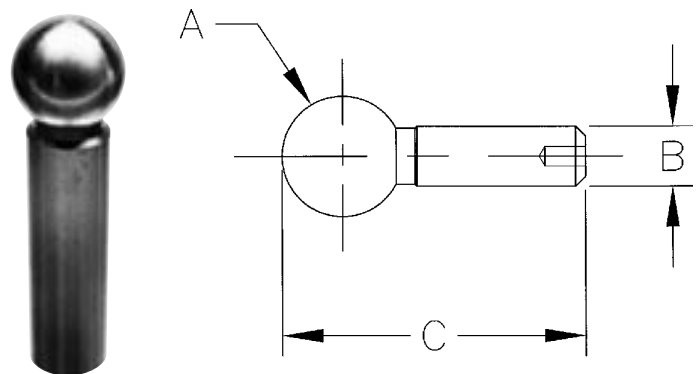

Slip Fit

Part No.	Dia. A*	Dia. B**	C	Weight (lbs/100pcs)
11201	0.2500	0.1250	9/16	1
11202	0.3750	0.1875	3/4	1
11203	0.5000	0.2500	15/16	3
11204	0.5000	0.2500	1-1/2	3
11205	0.5000	0.3750	1-1/2	8

*A Diameter: $\pm .0002$
 **B Diameter: $+ .0000 / - .0004$

Construction Ball Shoulder Construction Ball

- Used as reference points for inspection applications in conjunction with Coordinate Measuring Machines to accurately measure the workpiece
- Concentricity of Ball to Shank - .0002 T.I.R.
- Hardened and ground steel (8620 Stainless)
- One-piece construction

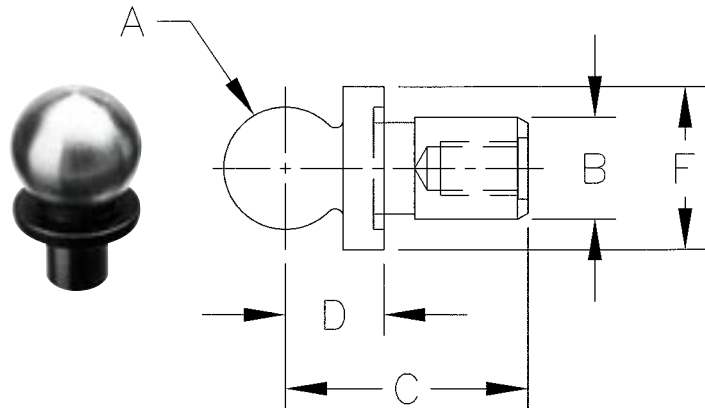

English

Part No.	Dia. A*	Dia. B**	C	D***	Dia. F	Weight (lbs/100pcs)
11001*	.5000	.2500	5/8	0.3125	1/2	3
11002	.5000	.2500	5/8	0.3125	1/2	3

*A Diameter: $\pm .0002$

**B Diameter: $\pm .0000 / -.0004$

***D: $\pm .0002$

* 6-32 UNC-2B x 3/16 deep tapped shank as shown.

Metric

Part No.	Dia. A*	Dia. B**	C	D***	Dia. F	Weight (lbs/100pcs)
11020	6mm	3mm	16mm	6mm	6mm	1
11021	10mm	5mm	20mm	10mm	10mm	3
11022	12mm	6mm	22mm	12mm	12mm	3

*A Diameter: $\pm .005\text{mm}$

**B Diameter: $\pm .000 / -.010\text{mm}$

***D: $\pm .005$

Carbide Ball

- Material:
 - Ball: Carbide
 - Shank: 440 Stainless
- Used as reference points for inspection applications in conjunction with Coordinate Measuring Machines to accurately measure the workpiece
- Concentricity of Ball to Shank - .0002 T.I.R.
- Two-piece construction
- Weight per 100 pcs. is less than one pound

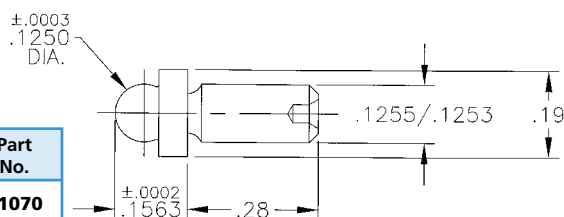

Part No.
11070

Tooling Ball Cover

- Protects tooling and inspection balls from damage between operations.
- Low cost solution to protect tooling ball investment
- Made of a durable, high impact resistant Polymer
- Mounts over .875" diameter or smaller tooling ball directly into jig fixture with two number 10 screws



Part No.	Max. Tooling Ball Size
10600	.875" Dia. Ball