

# Spindle Identification

For Mounting Plates

## SPINDLE TYPE A1 & A2

Spindle nose A	B	C (MAX)	E1 & E2	F1	F2
A-4	2.500	0.437	7/16"-14	3.250	-----
A-5	3.251	0.563	7/16"-14	4.125	2.437
A-6	4.188	0.625	1/2"-13	5.250	3.250
A-8	5.501	0.688	5/8"-11	6.750	4.375
A-11	7.751	0.750	3/4"-10	9.250	6.500
A-15	11.251	0.813	7/8"-9	13.000	9.750
A-20	16.251	0.875	1"-8	18.250	14.500
A-28	23.001	1.000	1-1/4"-7	25.500	10.438

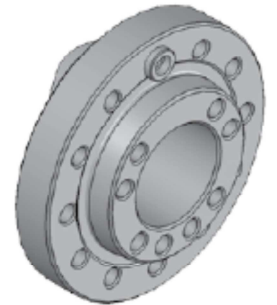
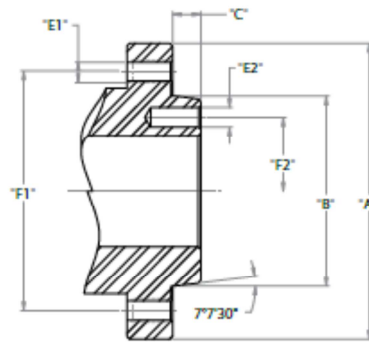

## L SPINDLE TYPE LONG TAPER KEY DRIVE

Spindle nose A	THREAD B	C	KEY
L00	3-3/4"-6	2.000	3/8 X 3/8 X 1-1/2
L0	4-1/2"-6	2.375	3/8 X 3/8 X 1-3/4
L1	6"-6	2.875	5/8 X 5/8 X 2-3/8
L2	7-3/4"-5	3.375	3/4 X 3/4 X 2-7/8
L3	10-3/8"-4	3.875	1.00 X 1.00 X 3-1/4

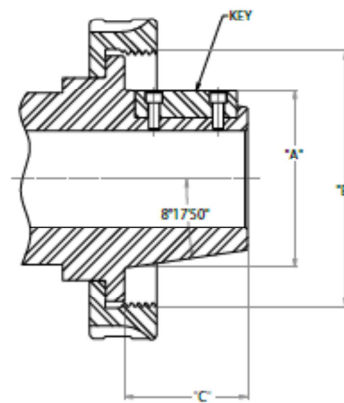

## THREADED SPINDLE TYPE

Spindle nose thread  
A

1"-8

1"-10

1-1/2"-8

1-3/4"-8

2-1/4"-8

2-3/8"-6

2-3/4"-8

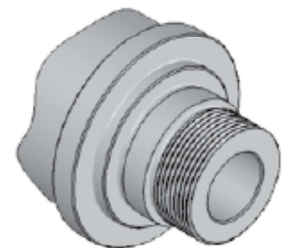
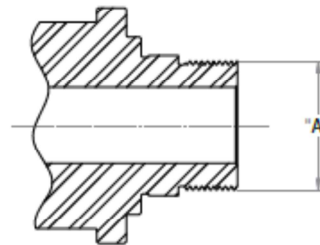

## D1 CAMLOCK SPINDLE TYPE

Spindle nose A	B	C (MAX)	CAMSTUD DIA "E"	F
D1-3	2.125	0.437	9/16	2.782
D1-4	2.500	0.437	5/8	3.250
D1-5	3.251	0.500	3/4	4.125
D1-6	4.188	0.625	7/8	5.250
D1-8	5.501	0.688	1	6.750
D1-11	7.751	0.750	1-3/16	9.250
D1-15	11.251	0.813	1-3/8	13.000

